



Variante B (flächenbündiger Einbau - flush-mount installation)

- Modul Spule auf Generator als kompakte Einheit - inductor on the generator as compact unit
- getrennt Spule und Generator getrennt - inductor and generator are separate
 Spule auf Spulenträger - inductor on plate for induction
 Generator in seperatem Anschlußfach - generator in a separate case
 Kabellänge variabel bestellbar - cable length to order variable

	NAME	DATUM	SIG.	alle Maße in mm	DATUM	SIG.	INDEX	ÄNDERUNG	
GEZEICHNET	Adolf	25.08.2018	MA	 Allgemeintoleranz = m	25.08.2018	MA	a		
GEPRÜFT								b	
							c		
							d		
 Berner								BENENNUNG:	
								BI4EGAFL30K_B	
Berner-Kochsysteme GmbH & Co.KG Sudetenstr.5 D-87471 Durach www.induktion.de								ZEICHNUNGSNR.	MASSTAB: 1:10
								BI6EGAFL30K_B	A3
BLATT 1 VON 3									

Vorderansicht/ front view

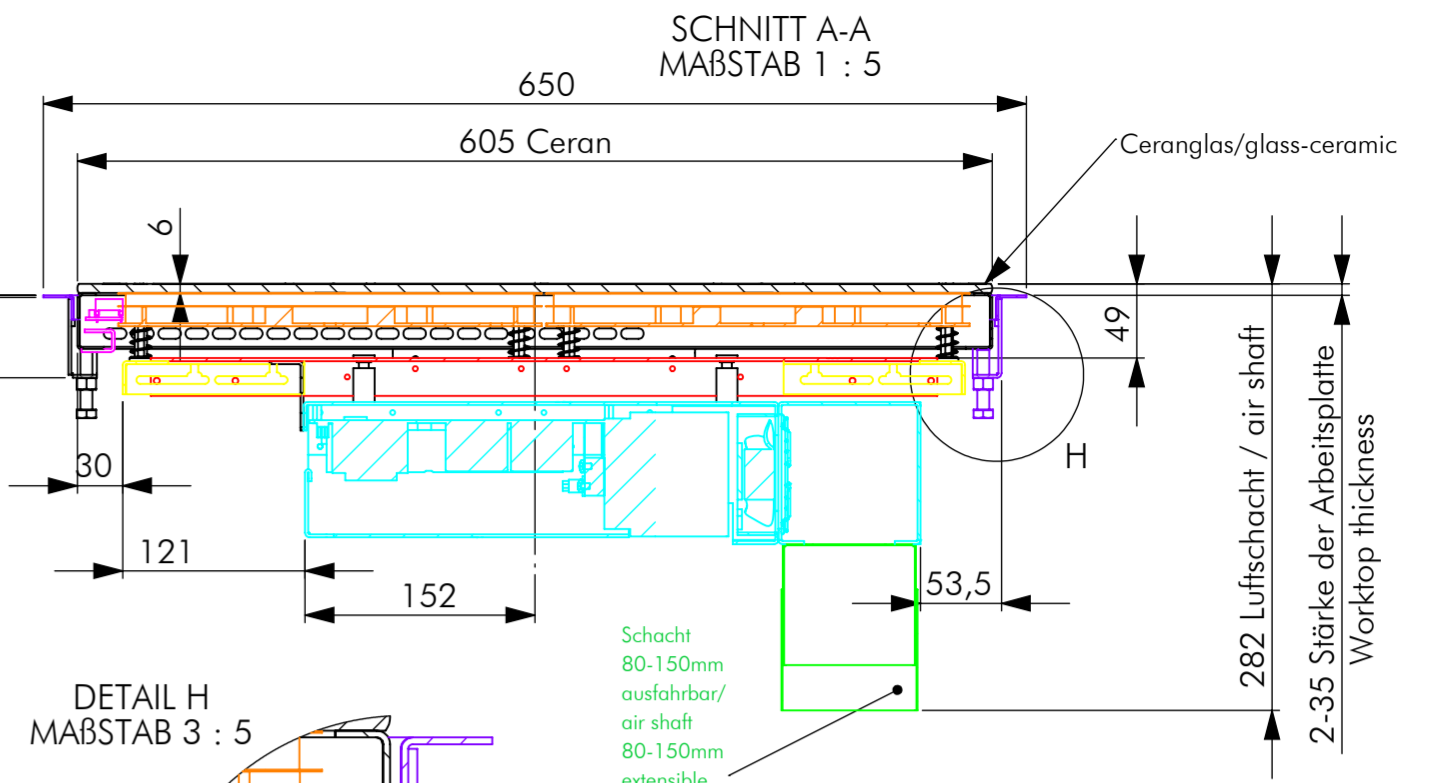
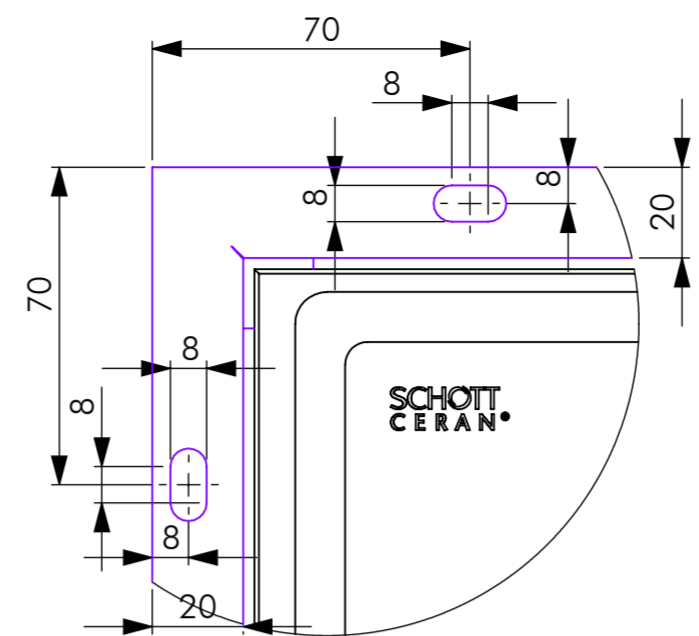
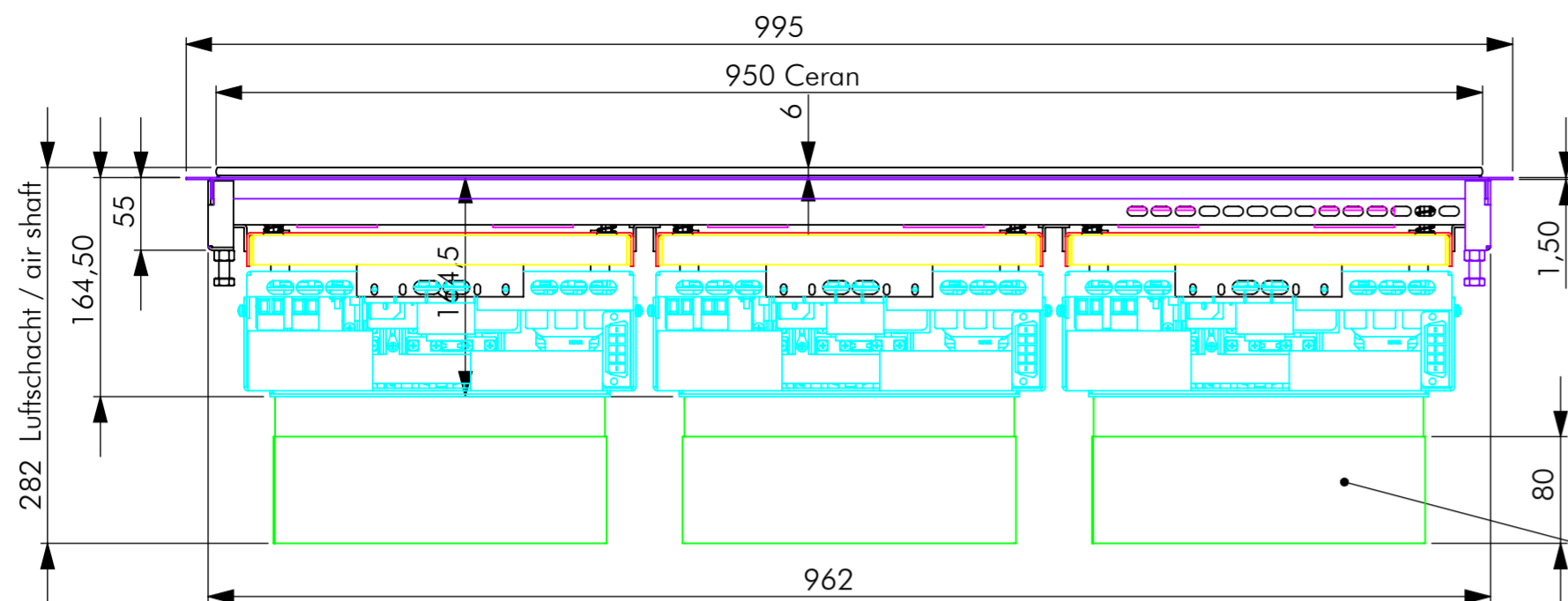

Draufsicht/ top view

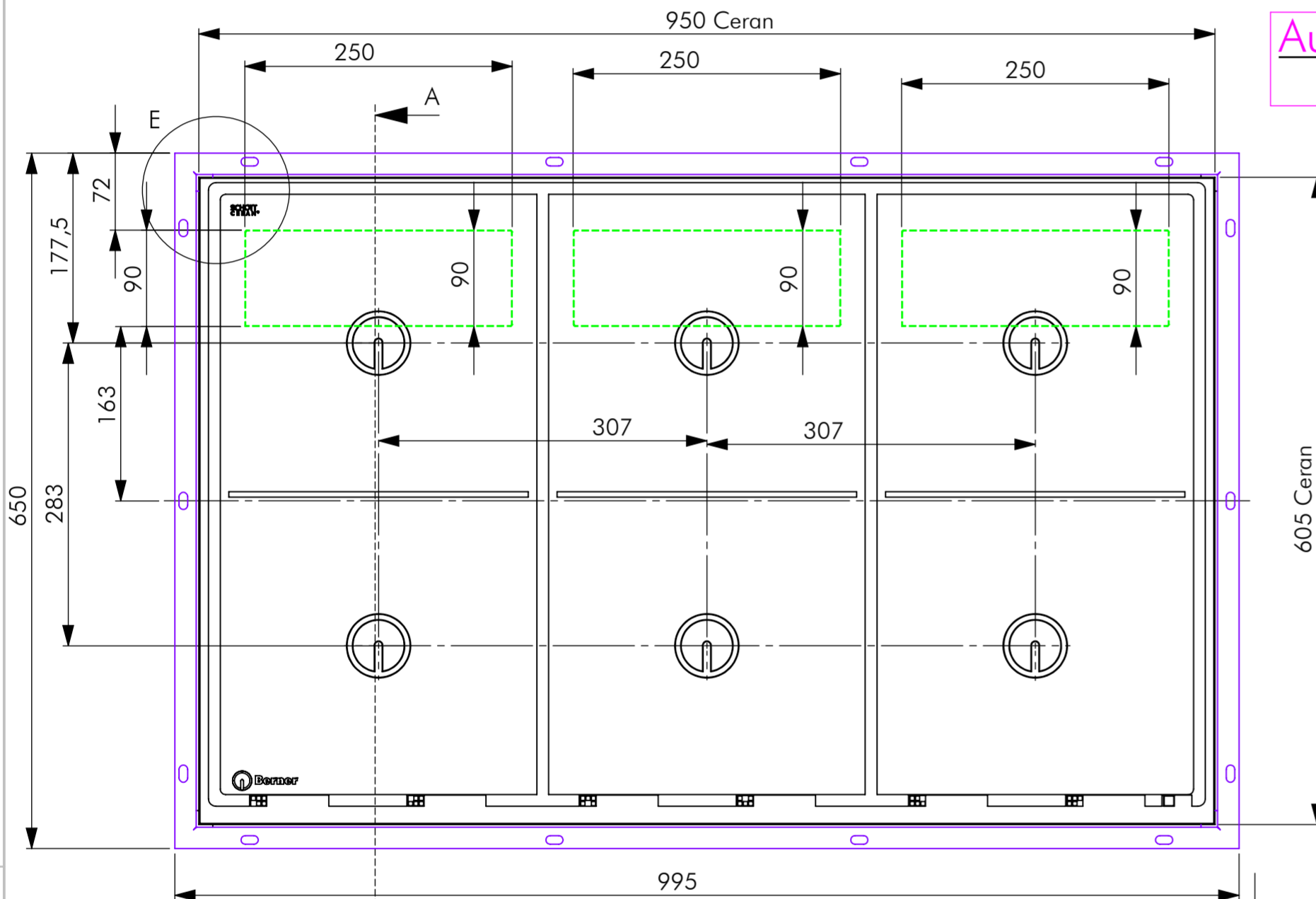

Ausschnitt in Abdeckung 956 x 611
cut out at cover panel

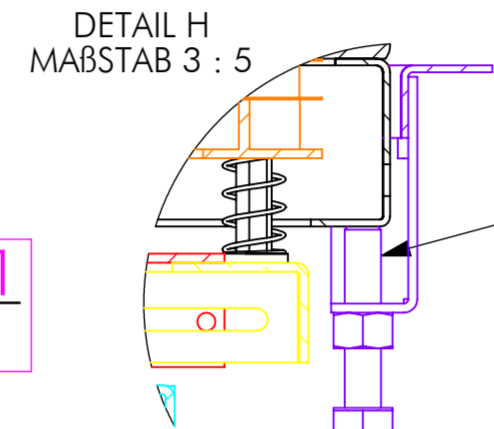

Standard Schraube M8x40 für eine Arbeitsplattenstärke bis 35mm / Standard screw M8x40 for Worktop thickness until 35mm

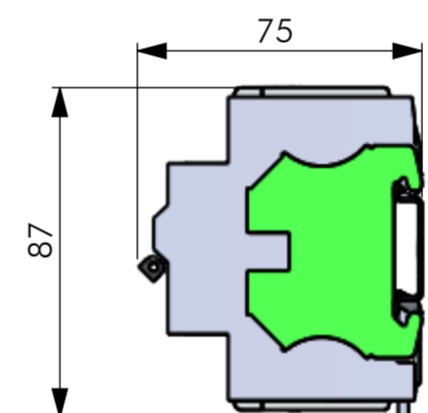

Schalterblende (optional lieferbar)
switch panel - optional available

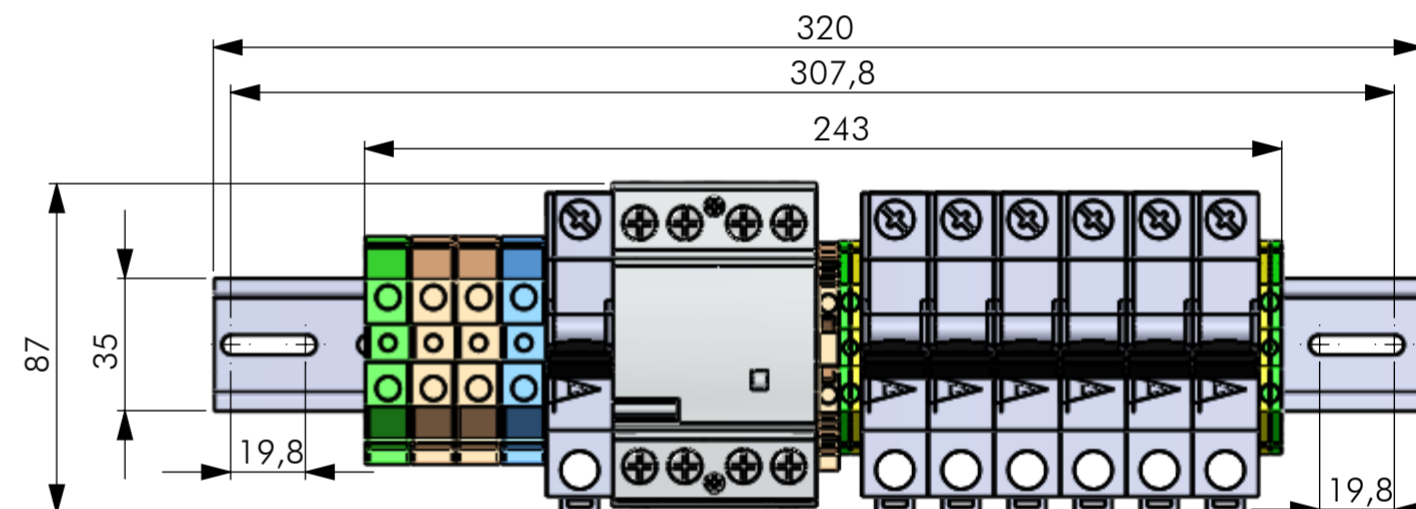

Platz für die Schaltung in Unterbau vorsehen, bei getrennter Montage max. 2,0m von Generatoren
provide space for the circuit in base, if installed separately from max. 2,0 m of generator

Generatoransicht generator view

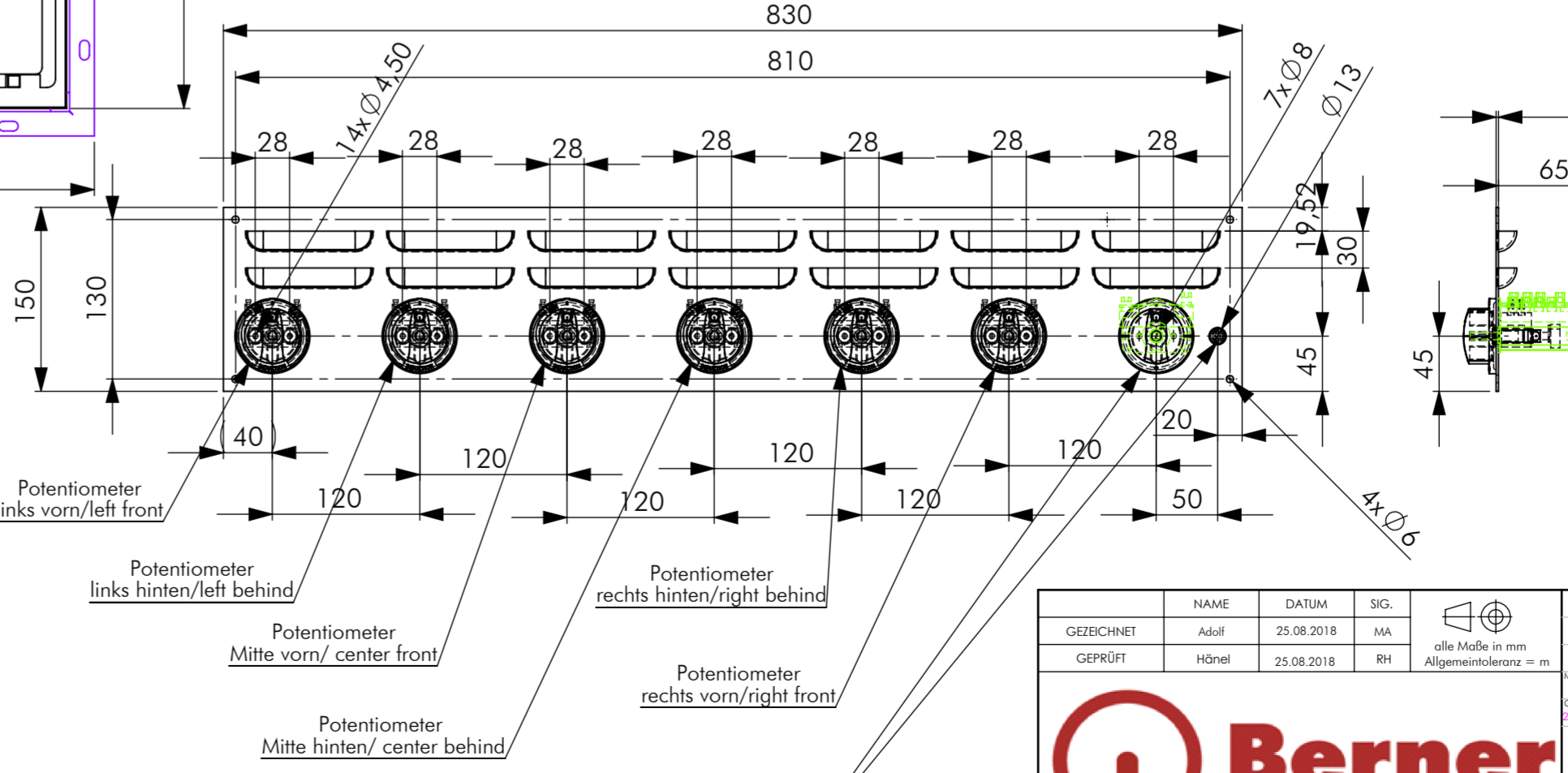
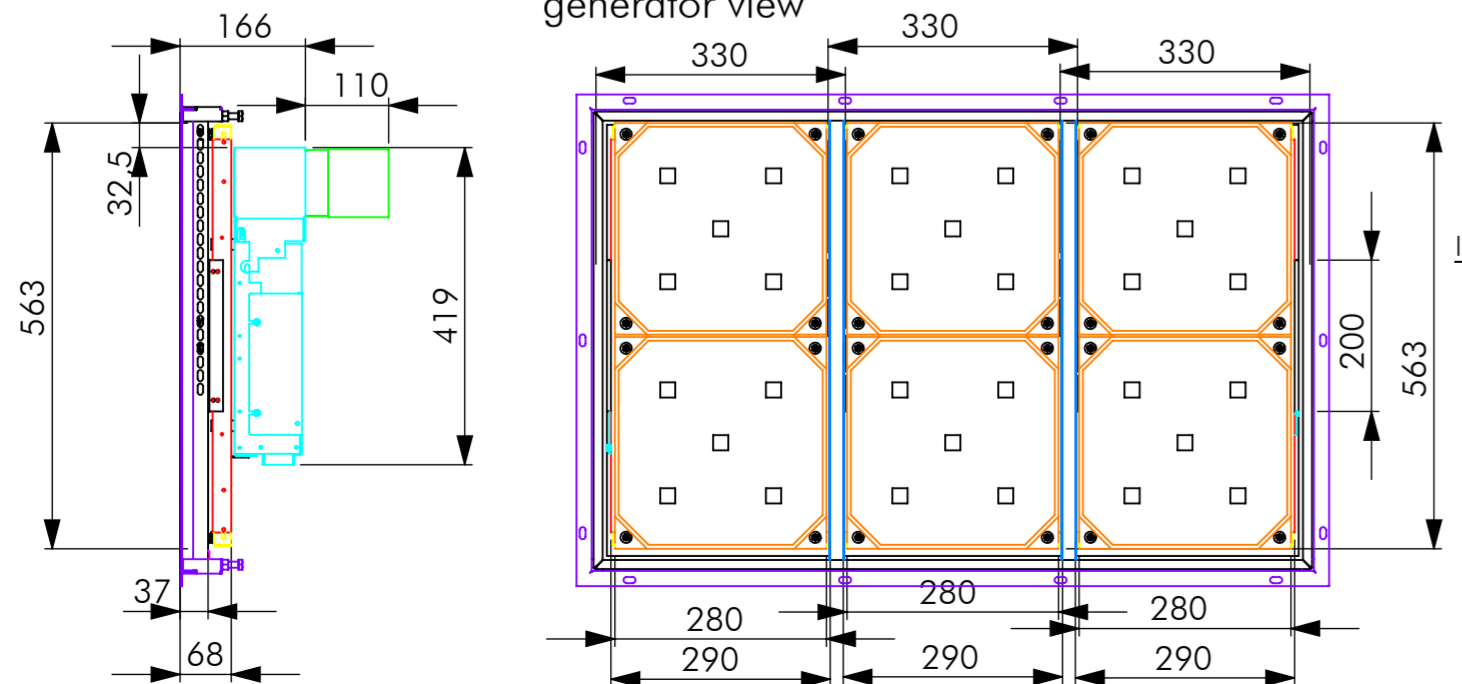

- Linien-Legende / line-key
- Generator / generator
- Induktion / induction
- Luftschacht / air shaft
- Rahmen / frame
- Ver.-Rahmen / con.frame
- Erweiterungsblech / extension plate
- Hauptschalter / main switch
- Spulenträger / plate for induction
- Anzeige/ display
- Mittelstrebe/crossbar

Hauptschalter mit Betriebsleuchte grün 230V
main switch with green lamp for starting 230V

GEZEICHNET	NAME	DATUM	SIG.	alle Maße in mm Allgemeintoleranz = m	DATUM	SIG.	INDEX	ÄNDERUNG
GEPRÜFT	Adolf	25.08.2018	MA		25.08.2018	MA	a	-
	Hänel	25.08.2018	RH			b		
						c		
						d		



Variante_B flächenbündig Modul
version B flush-mount modular unit

Berner-Kochsysteme GmbH & Co.KG
Sudetenstr.5 D-87471 Durach
www.induktion.de

RECHNUNGSNR.: BI6EGAFL30K_B
MASSSTAB 1:10
BLATT 2 VON 3
A2

Vorderansicht/ front view

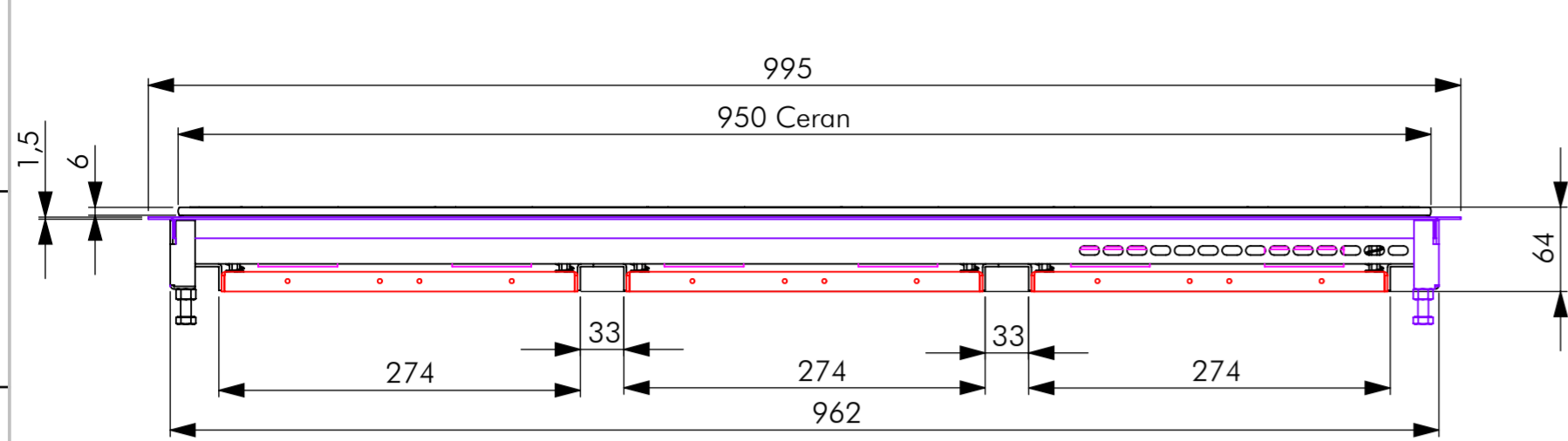

Draufsicht/ top view

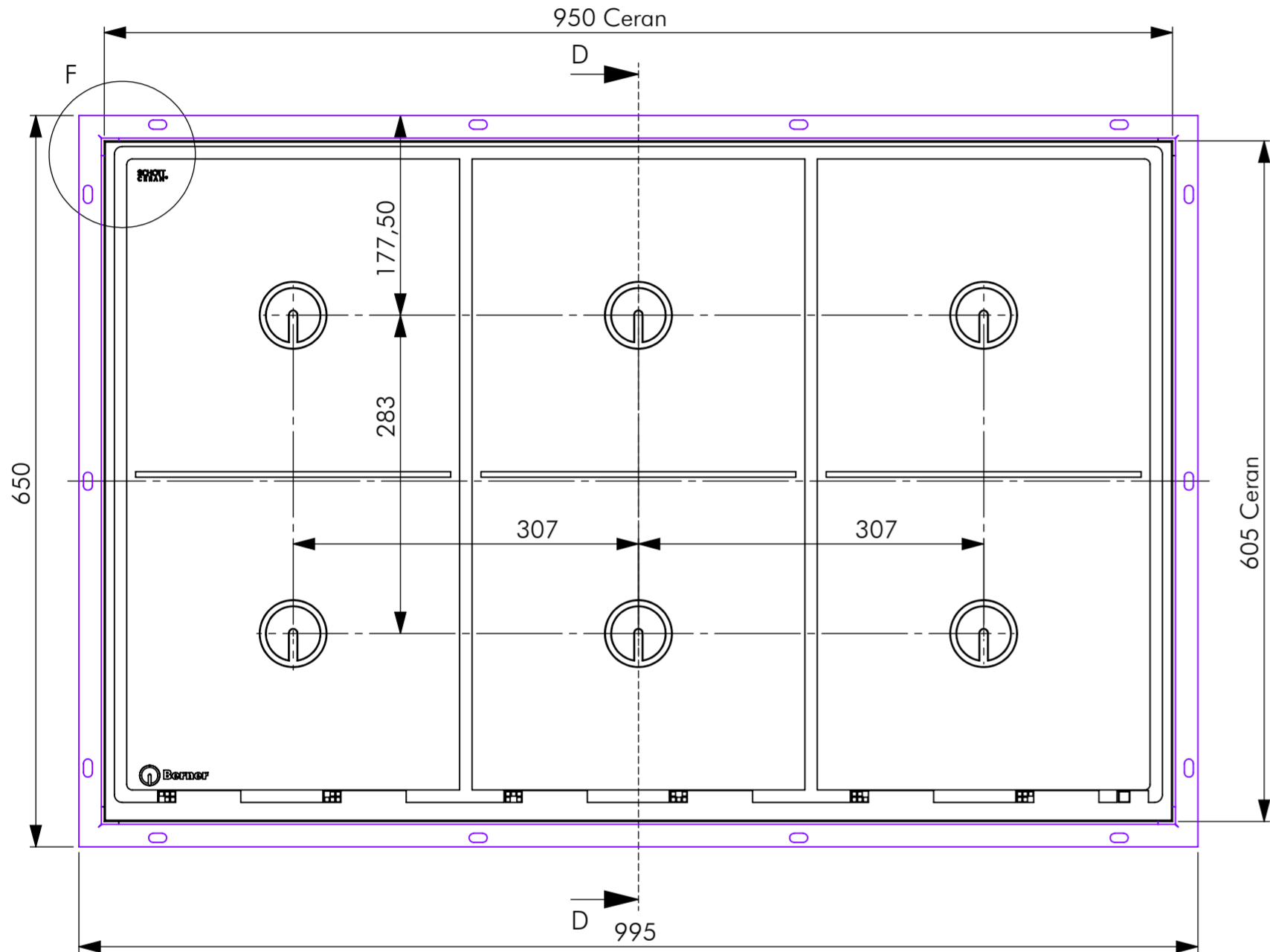

DETAIL F
MABSTAB 3 : 5

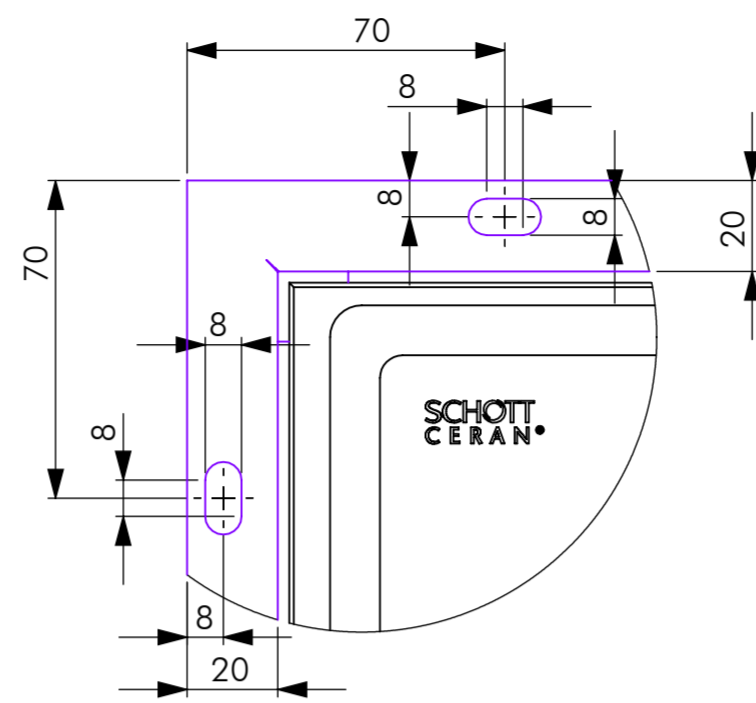

SCHNITT D-D
MABSTAB 1 : 5

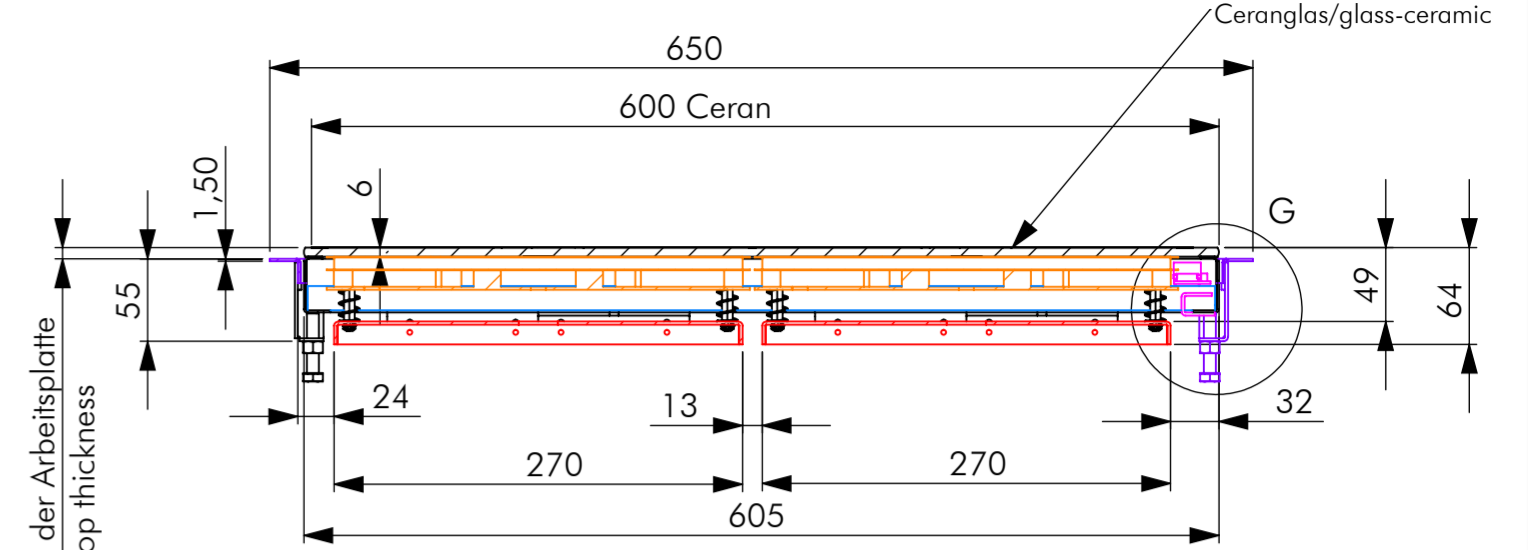

DETAIL G
MABSTAB 3 : 5

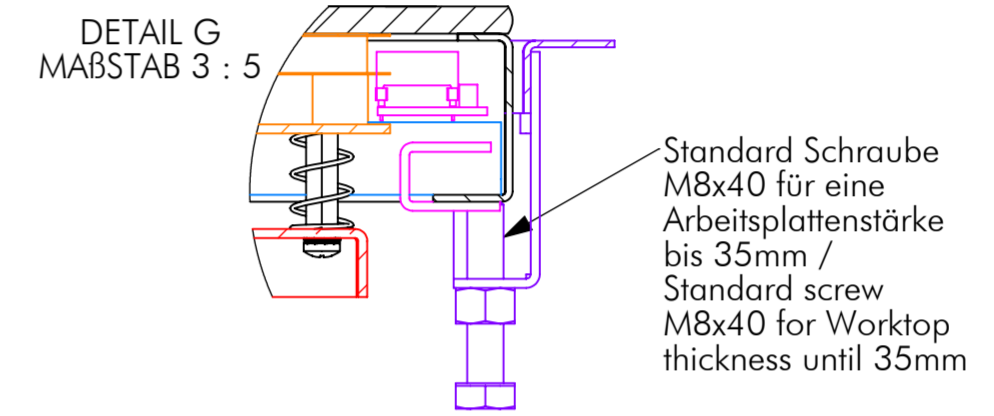

Ausschnitt in Abdeckung 956 x 611
cut out at cover panel

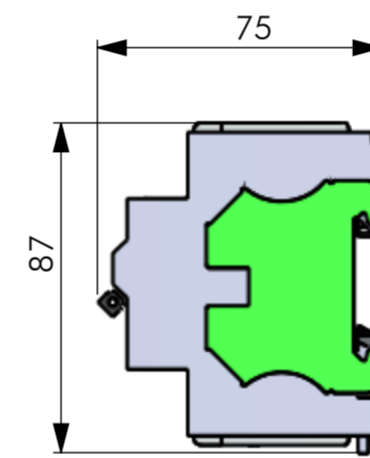

Schalterblende (optional lieferbar)
switch panel - optional available

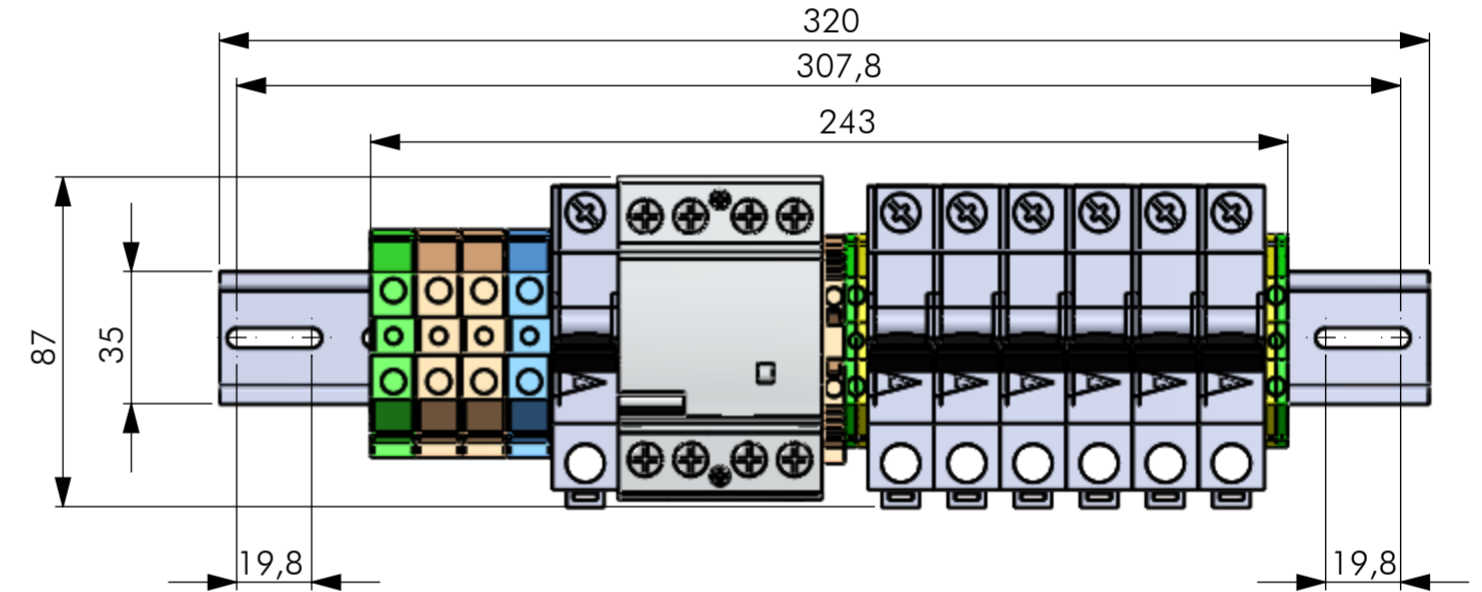

Platz für die Schaltung in Unterbau vorsehen,
bei getrennter Montage max. 2,0m von Generatoren
provide space for the circuit in base, if installed separately from max.2,0 m of generator

Generatoransicht
generator view

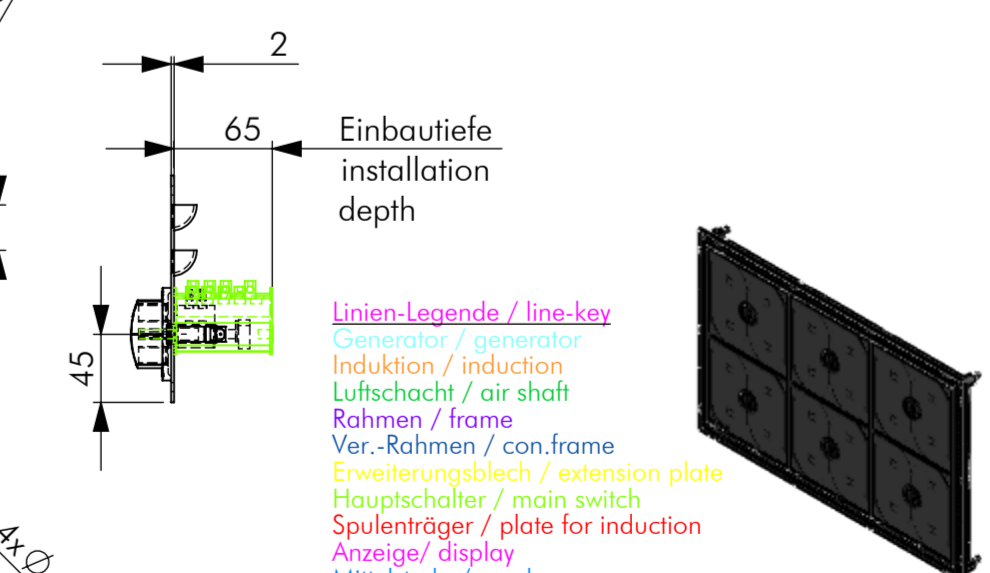
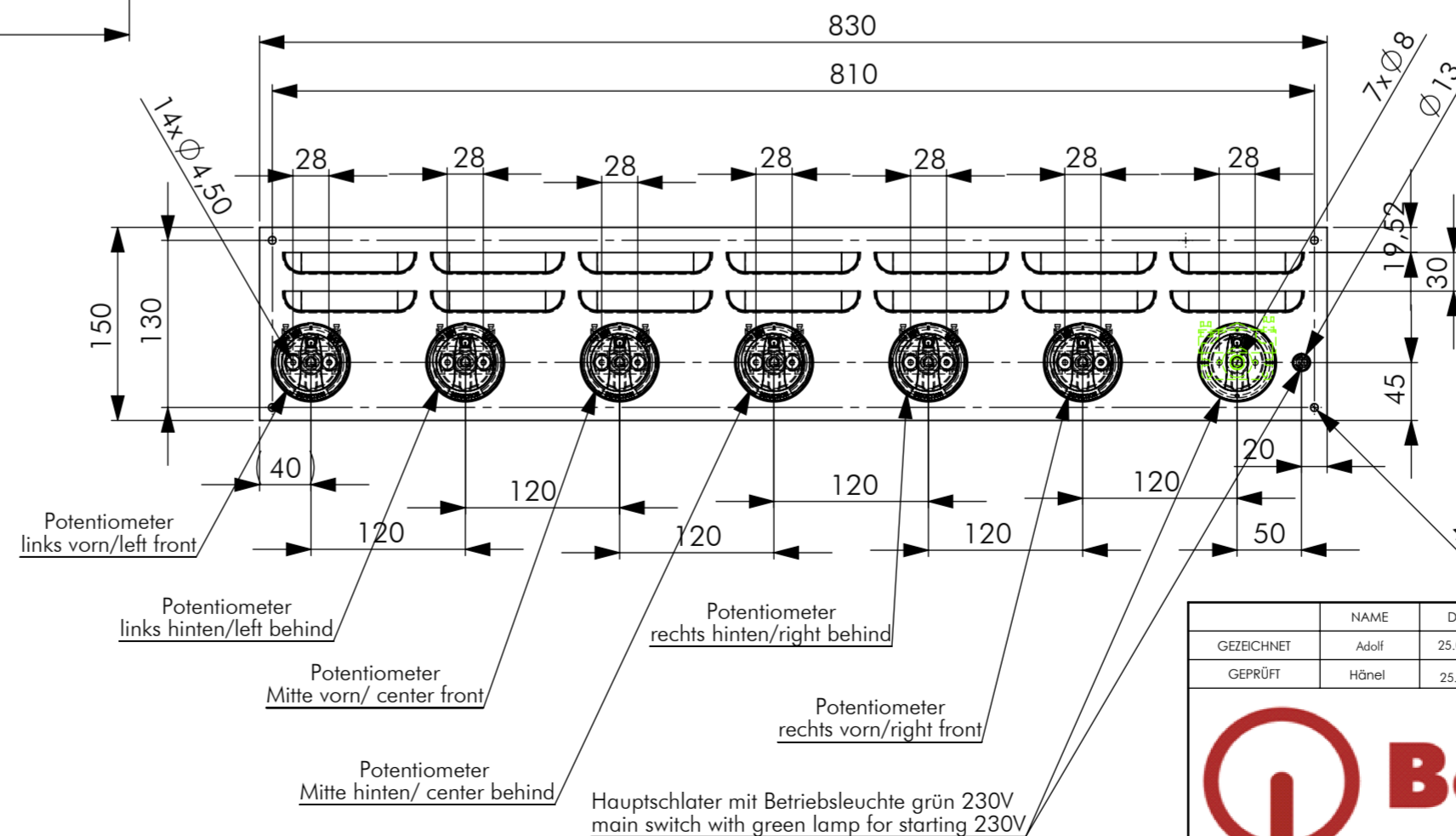
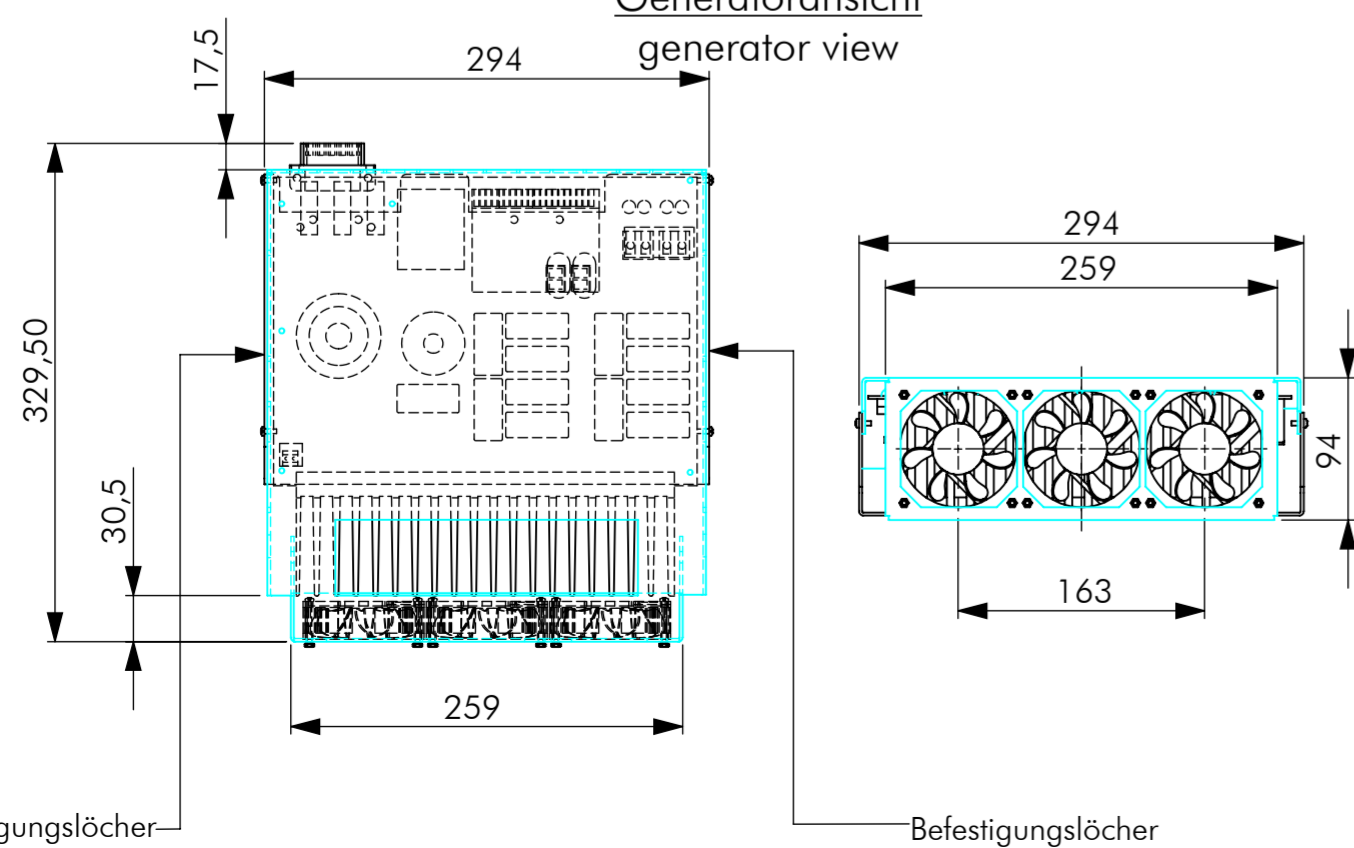

- Linien-Legende / line-key
- Generator / generator
- Induktion / induction
- Luftschacht / air shaft
- Rahmen / frame
- Ver.-Rahmen / con.frame
- Erweiterungsblech / extension plate
- Hauptschalter / main switch
- Spulenträger / plate for induction
- Anzeige/ display
- Mittelstrebe/crossbar

GEZEICHNET	NAME	DATUM	SIG.	ALLE MAßE IN MM Allgemeintoleranz = m	DATUM	SIG.	INDEX	ÄNDERUNG
GEPRÜFT	Adolf	25.08.2018	MA		25.08.2018	MA	a	
	Hönel	25.08.2018	RH				b	
							c	
							d	



Variante_B flächenbündig getrennt
version B flush-mount separated

Berner-Kochsysteme GmbH & Co.KG
Sudetenstr.5 D-87471 Durach
www.induktion.de

ZEICHNUNGSNR: BI6EG AFL30K_B
MASSSTAB 1:10
BLATT 3 VON 3